

54" Galvanized Mega Flow Butterfly Fan

Installation and Operation Manual

PNEG-1502

Version 3.1

Date: 07-19-16



All information, illustrations, photos, and specifications in this manual are based on the latest information available at the time of publication. The right is reserved to make changes at any time without notice.

Contents

Chapter 1	Safety Cautions	5
	Safety Guidelines	5
	Cautionary Symbol Definitions.....	6
	Safety Precautions	7
	Safety Decals	11
	Safety Sign-off Sheet.....	12
Chapter 2	General Information	13
	General Description.....	13
	Main Assemblies	14
	General Specification	14
Chapter 3	Assembly	15
	Framing and Positioning	16
	Fan Cabinet Assembly.....	18
	Motor and Belt Installation.....	21
	Tabbed Cone Panel Assembly.....	23
	Butterfly Assembly	26
	Grill Guard Assembly.....	29
	Inlet Grill Assembly.....	30
	Inlet Bell Assembly	31
	Electrical Connection.....	33
Chapter 4	Operation and Maintenance	35
	Start-Up Operation	35
	Maintenance	35
Chapter 5	Troubleshooting	37
	Troubleshooting Guide	37
Chapter 6	Parts List	39
	54 in. Mega Flow Fan Parts.....	39
	GSI Group, LLC Limited Warranty	43

All information, illustrations, photos, and specifications in this manual are based on the latest information available at the time of publication. The right is reserved to make changes at any time without notice.

1 Safety Cautions

Topics Covered in this Chapter

- Safety Guidelines
- Cautionary Symbol Definitions
- Safety Precautions
- Safety Decals
- Safety Sign-off Sheet

Safety Guidelines

Safety guidelines are general-to-specific safety rules that must be followed at all times. This manual is written to help you understand safe operating procedures and problems that can be encountered by the operator and other personnel when using this equipment. Save these safety guidelines for future reference.

As owner or operator, you are responsible for understanding the requirements, hazards, and precautions that exist and to inform others as required. Unqualified persons must stay out of the work area at all times.

Alterations must not be made to the equipment. Alterations can produce dangerous situations resulting in **SERIOUS INJURY** or **DEATH**.

This equipment must be installed in accordance with the current installation codes and applicable regulations, which must be carefully followed in all cases. Authorities having jurisdiction must be consulted before installations are made.

When necessary, you must consider the installation location relative to electrical, fuel and water utilities.







Personnel operating or working around equipment must read this manual. This manual must be delivered with equipment to its owner. Failure to read this manual and its safety instructions is a misuse of the equipment.

ST-0001-3

Cautionary Symbol Definitions

Cautionary symbols appear in this manual and on product decals. The symbols alert the user of potential safety hazards, prohibited activities and mandatory actions. To help you recognize this information, we use the symbols that are defined below.

Table 1-1 Description of the different cautionary symbols

Symbol	Description
	This symbol indicates an imminently hazardous situation which, if not avoided, will result in serious injury or death.
	This symbol indicates a potentially hazardous situation which, if not avoided, can result in serious injury or death.
	This symbol indicates a potentially hazardous situation which, if not avoided, can result in minor or moderate injury.
	This symbol is used to address practices not related to personal injury.
	This symbol indicates a general hazard.
	This symbol indicates a prohibited activity.
	This symbol indicates a mandatory action.

ST-0005-2

Safety Precautions

Use Personal Protective Equipment

- Use appropriate personal protective equipment:

Eye Protection



Respiratory Protection



Foot Protection



Hearing Protection



Head Protection



Fall Protection



Hand Protection



- Wear clothing appropriate to the job.
- Remove all jewelry.
- Tie long hair up and back.

ST-0004-1

Follow Safety Instructions

- Carefully read all safety messages in this manual and safety signs on your machine. Keep signs in good condition. Replace missing or damaged safety signs. Be sure new equipment components and repair parts include the current safety signs. Replacement safety signs are available from the manufacturer.
- Learn how to operate the machine and how to use controls properly. Do not let anyone operate without instruction.
- If you do not understand any part of this manual or need assistance, contact your dealer.



ST-0002-1

Lifting Hazard

- Single person lift can cause injury.
- Use a mechanical lifting device to lift or move the equipment during installation.



ST-0021-2

Explosion Hazard

- The fan is not designed for use in atmospheres where the risk of explosion is present.
- Do not use the fan in enclosed areas of high dust concentrations, flammable gas, vapors or fumes.



ST-0022-1

Keep Hands Away from Moving Parts

- Do not operate the fan with electrical or mechanical guards removed. Serious injury or death can result.
- Do not put hand or arm in fan. Rotating parts can crush and dismember.
- Do not put any kind of tool inside the fan to clear debris while the fan is operating. Damage to the equipment will result.
- Lock-out power source before making adjustments, cleaning, or maintaining equipment.

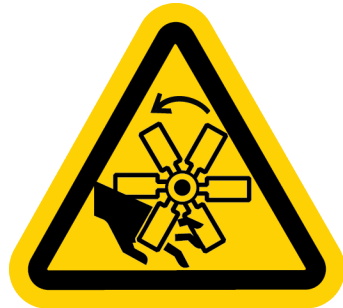

ST-0020-2

Install and Operate Equipment Properly

- The fan described in this manual is designed solely for the purpose of ventilating agricultural buildings. Use of the fan in any other way is a misuse of the equipment and may endanger health and safety.



ST-0023-1

Install and Operate Fan Properly

- Electrical controls and wiring must be installed by a qualified electrician and must meet the standards set by the National Electric Code, Canadian Electrical Code, and all local and state codes. The fan must be installed and maintained by a qualified person familiar with the use and function of ventilation fans.
- Lock-out power source before making adjustments, cleaning, or maintaining equipment.
- Do not operate fan unless the motor is properly grounded. Grounding can be achieved by wiring with a grounded conduit or a separate ground wire attached to the motor ground lug.
- Do not operate the fan by bypassing any safety device on the unit.
- Do not kink power cables and do not allow cables to come into contact with oil, grease, hot surfaces or chemicals.
- Motor overload protection must be provided with each single phase fan. A circuit breaker or slow blow motor type fuse must be used. A safety cut-off switch must be located adjacent to each fan.
- Fans used to ventilate livestock buildings and other rooms where continuous air movement is essential must be connected to individual electrical circuits with a minimum of two (2) circuits per room.
- Installation of supplementary natural ventilation, back-up thermostat and an alarm system on at least one cooling stage is recommended. See diagram on motor nameplate and information provided with fan control (if used) for connection requirements.



ST-0018-2

Sharp Edge Hazard

- This product has sharp edges, which can cause serious injury.
- To avoid injury, handle sharp edges with caution and always use proper protective clothing and equipment.



ST-0036-2

Maintain Equipment and Work Area

- Do not attempt maintenance or repairs on the fan unless you are competent to do so. Understand service procedures before doing work.
- Use only genuine Cumberland parts when maintaining the fan. Use of other non-genuine parts is a misuse and can lead to dangerous situations.
- Be aware that the fan may operate under automatic control and may start without warning.
- Lock-out power source before making adjustments, cleaning, or maintaining equipment.
- Keep area clean and dry.
- Keep hands, feet, and clothing away from moving parts.
- Keep the fan in proper working condition. Replace worn or broken parts immediately.
- Keep the fan clean. Do not allow debris to collect around motors, belts, pulleys or bearings.
- Make sure that all electrical enclosures and guards are closed and locked before re-starting the fan.



ST-0019-2

Safety Decals

The safety decals on your equipment are safety indicators which must be carefully read and understood by all personnel involved in the installation, operation, service and maintenance of the equipment.

Location	Decal No.	Decal	Description
Left and right middle, inside and outside	DC-2180		Non-text fan Warnings
Left middle outside and right middle inside	DC-1540		Danger High Voltage Warning Stay Clear of Rotating Blade Warning Flying Objects Hazard
Left middle outside and right middle inside	DC-995		Warning Shear Point

To replace a damaged or missing decal, contact us to receive a free replacement.

GSI Decals

1004 E. Illinois St.
 Assumption, IL 62510
 Tel: 1-217-226-4421

2 General Information

Topics Covered in this Chapter

- General Description
- Main Assemblies
- General Specification

General Description

The Mega Flow Butterfly Fans are equipped with a simple butterfly style shutter structure to improve the fan performance and stability. The butterfly style shutter eliminates small shutter blades that are prone to dust build-up and reduce air flow, while providing protection against harsh weather conditions such as wind and moisture while the fan is not in use.

During operation, the air forces the shutter doors to open. The magnetic shutter panel ring is used to alleviate the movement of the shutter while not in use.

The Mega Flow Butterfly Fan is belt driven and has a spring loaded belt tensioner to ensure proper belt tension.

Main Assemblies

Figure 2-1 54 in. Galvanized Mega Flow Butterfly Fan Main Assemblies

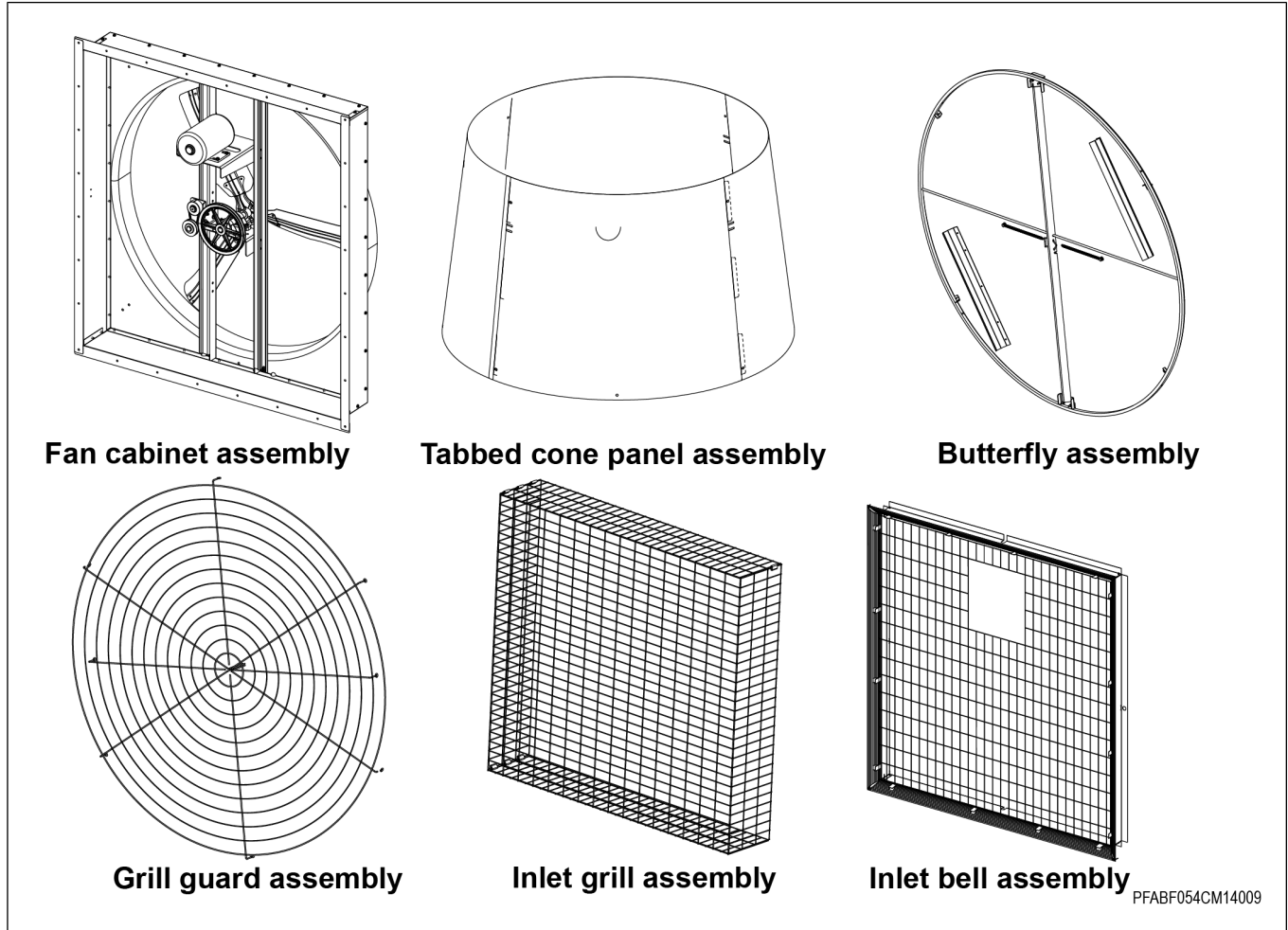

General Specification

Before beginning installation, check the condition of the fan. Remove the overwrap and packing materials and examine all parts and components for shipping damage. Any damage incurred must be reported immediately to the freight carrier.

Models	77-0143, 77-0144, 77-0145, 77-0146, 77-0147, 77-0148, 77-0149, 77-0150, 77-0151, 77-0152, 77-0153, 77-0154, 77-0155, 77-0156, 77-0157, 77-0158, 77-0159, 77-0160, 77-0161, 77-0162, 77-0163, 77-0164, 77-0165 and 77-0166
Size	54 in. Galvanized Mega Flow Butterfly Fan Housing and Cone
Voltage	115V/230V
Amps	16.0/8.0
Frequency	60 Hz Single Phase

3 Assembly

Topics Covered in this Chapter

- Framing and Positioning
- Fan Cabinet Assembly
- Motor and Belt Installation
- Tabbed Cone Panel Assembly
- Butterfly Assembly
- Grill Guard Assembly
- Inlet Grill Assembly
- Inlet Bell Assembly
- Electrical Connection

Framing and Positioning

Before You Begin

Make sure that you have enough rough opening and there is enough space so that the fan flanges do not overlap.

1. Construct the frame opening to 61–1/4 in. H x 58 in. W.

NOTE: Remember that the framing must be able to support the weight of the fan assembly. Ensure the load bearing portion of the bottom sill is rigid and properly supported.

2. Plan the layout and spacing of fans with cones; spacing fans too close together will cause interference with the cones.

Figure 3-1 54 in. Framed rough opening

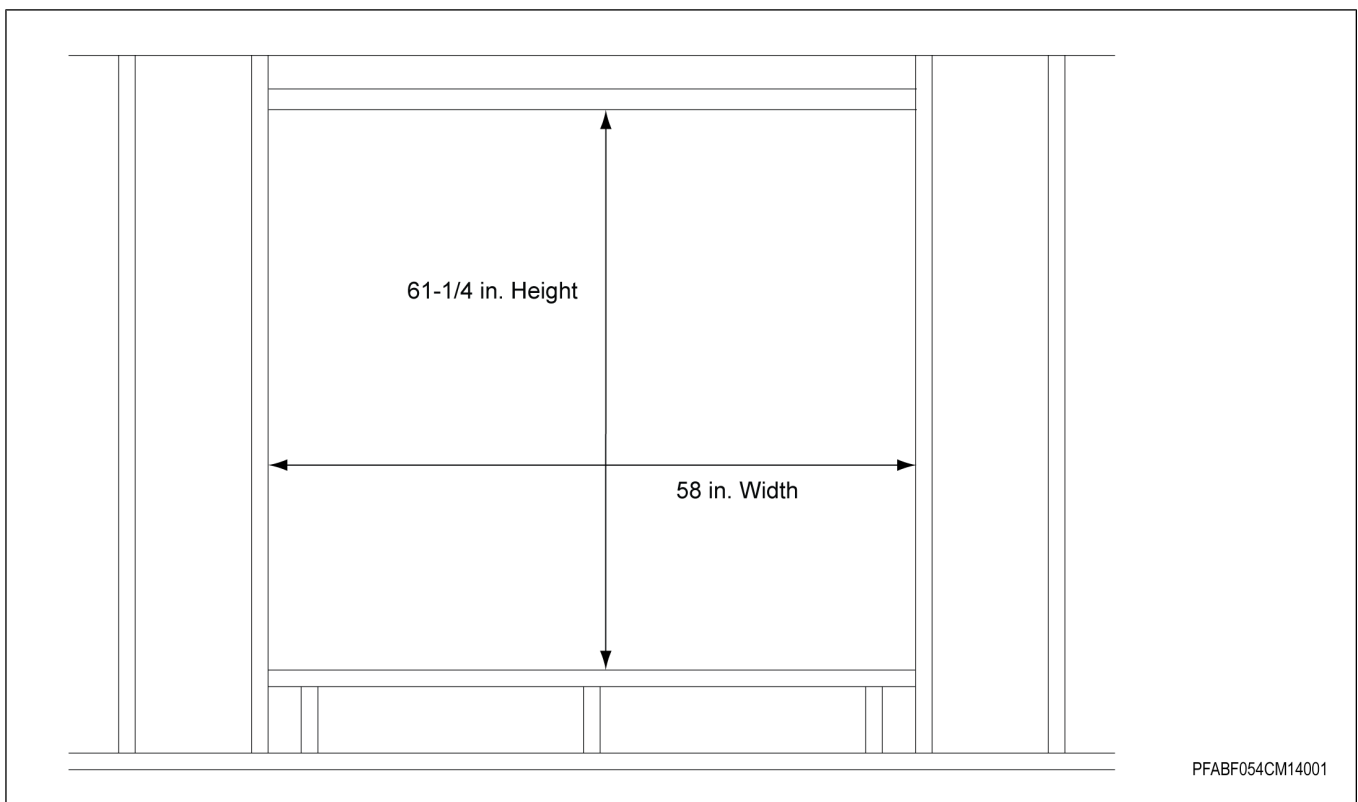

NOTE: 3/4 in. has been added for fan clearance.

Figure 3-2 Center to center fan spacing with cone

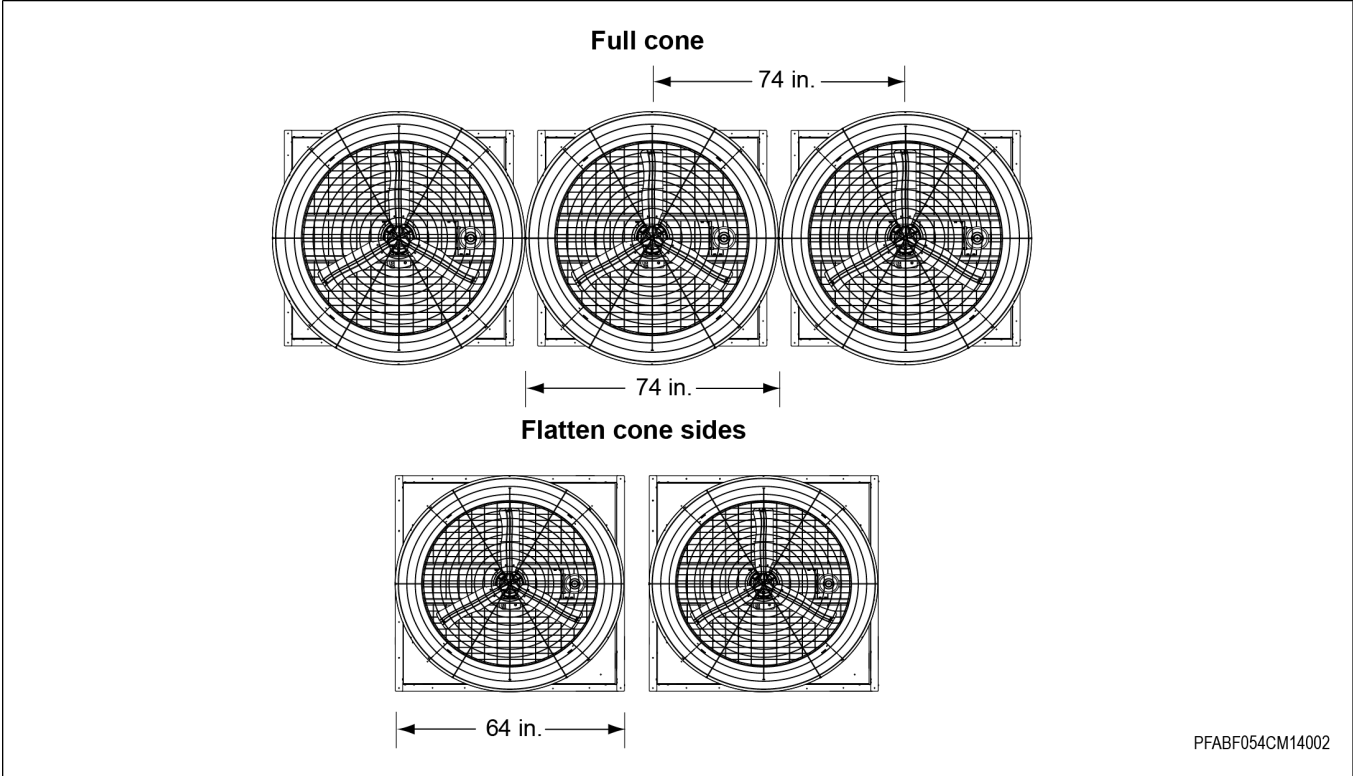

IMPORTANT: *The cone diameter is normally 74 in. diameter but the “Arches” in the side cone panels can be flattened giving a total of 64 in. side to side. See tabbed cone panel assembly for details. If not sure of sufficient clearance, contact your local distributor for more information.*

Fan Cabinet Assembly

1. Install the panels (A, B, C, and D) together with the screws (E).
2. Install the venturi (F) to the assembled panels with the screws (E).

NOTE: Make sure that the flanges of the panels overlap outside the venturi (F).

Figure 3-3 Assemble the panels

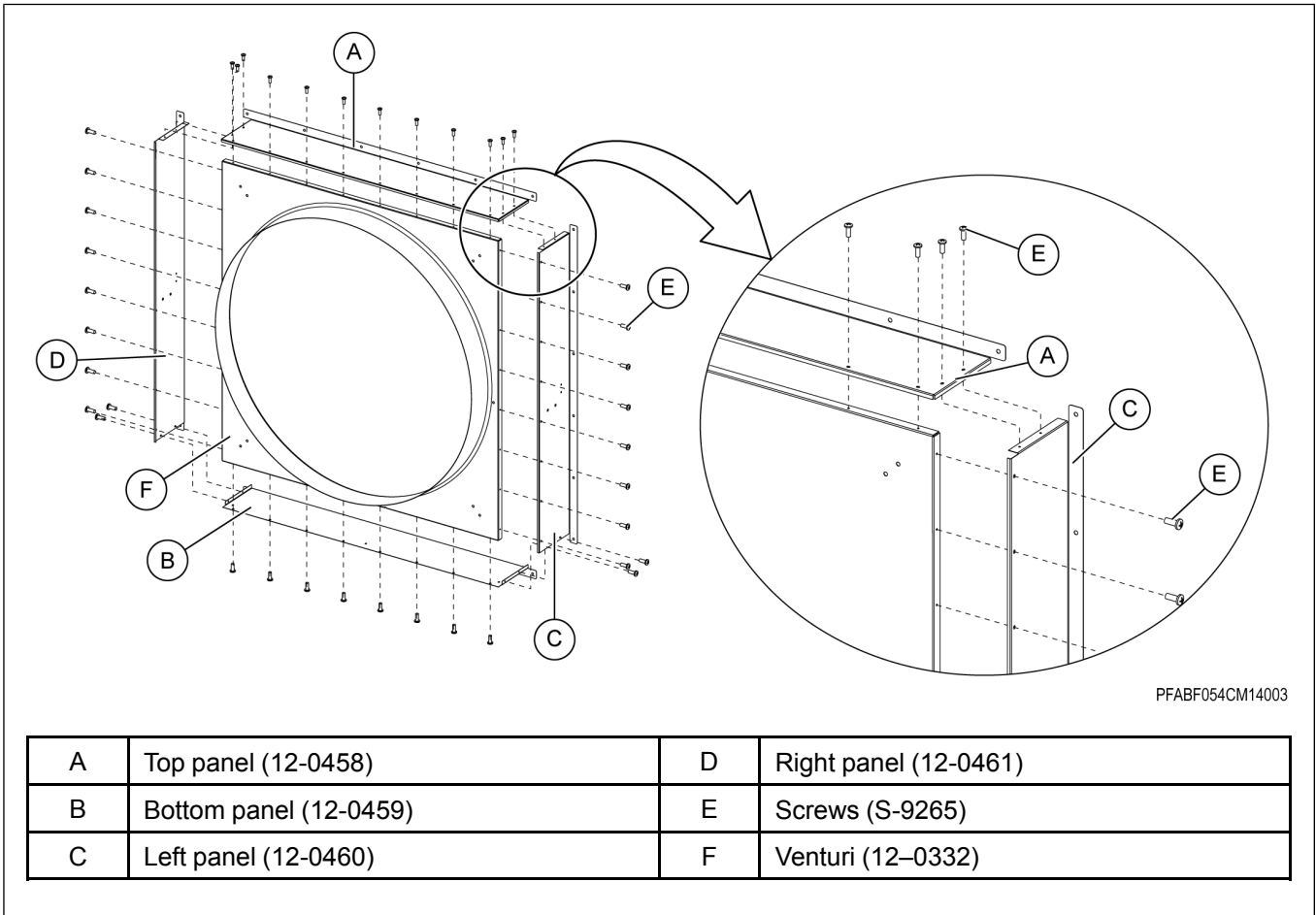

A	Top panel (12-0458)	D	Right panel (12-0461)
B	Bottom panel (12-0459)	E	Screws (S-9265)
C	Left panel (12-0460)	F	Venturi (12-0332)

3. Install the vertical braces (G) to the panels with the bolts (H) and nuts (I).

Figure 3-4 Assemble the vertical braces

The diagram illustrates the installation of two vertical braces (G) into a rectangular frame (F). The braces are positioned parallel to each other and perpendicular to the side panels. Bolts (H) are used to secure the braces to the side panels, with nuts (I) being attached to the ends of the bolts. Dashed lines indicate the alignment and placement of the components.

F	Venturi (12-0332)	H	Bolts (S-7485)
G	Vertical braces (12-0210)	I	Nuts (S-968)

PFABF054CM14004

4. Install the bearing bracket (J) to the vertical braces (G) with the bolts (H) and nuts (I).

Figure 3-5 Assemble the bearing bracket

The diagram shows a bearing bracket (J) being attached to the vertical braces (G). A circular inset provides a magnified view of the bracket being secured to the braces with bolts (H) and nuts (I). The main diagram shows the bracket's position relative to the entire assembly, with an arrow pointing to the inset for detail.

G	Vertical braces (12-0210)	I	Nuts (S-968)
H	Bolts (S-7485)	J	Bearing bracket (12-0212)

PFABF054CM14005

Chapter 3: Assembly

5. Install the bearings (K) to the bearing bracket (J) with the bolts (L), washers (M) and nuts (N).
6. Insert the shaft (O) through the bearings (K).
7. Align the keyways (T) and insert the pulley (P) on the shaft (O) with the key (Q). Secure the pulley (P) to the shaft (O) with the set screw (S).

NOTE: Make sure that the propeller is installed on the inside of the venturi.

8. Align the keyway (T) and insert the propeller (R) on the other end of the shaft (O).
9. Secure the propeller to the shaft with the prop screw (U).

Figure 3-6 Assemble the bearings

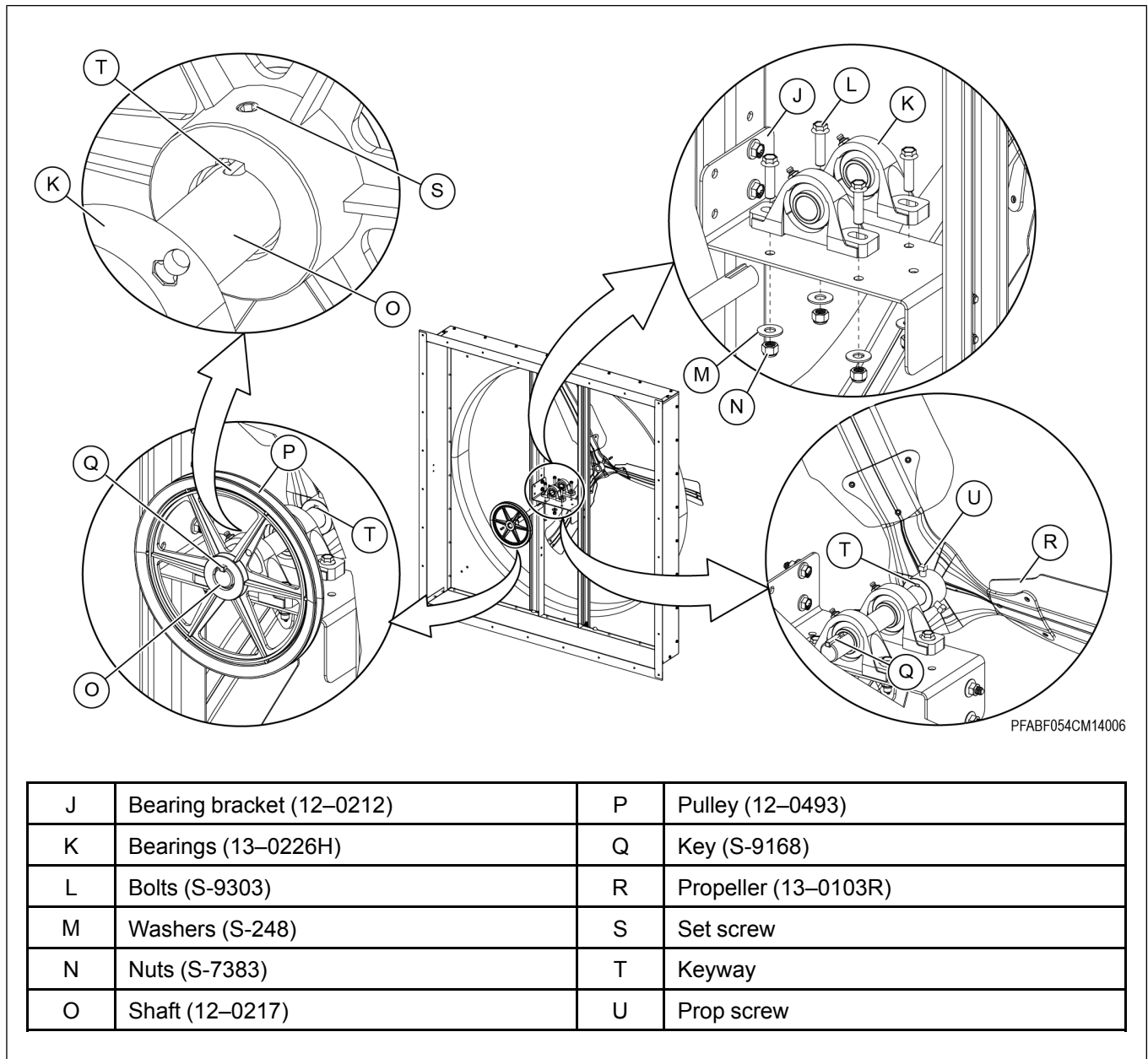

J	Bearing bracket (12-0212)	P	Pulley (12-0493)
K	Bearings (13-0226H)	Q	Key (S-9168)
L	Bolts (S-9303)	R	Propeller (13-0103R)
M	Washers (S-248)	S	Set screw
N	Nuts (S-7383)	T	Keyway
O	Shaft (12-0217)	U	Prop screw

Motor and Belt Installation

1. Install the motor mounting bracket (A) between the vertical braces (B) with the bolts (C) and nuts (D).

NOTE: Make sure the motor mount bracket (A) is installed above the bearing bracket. Also make sure that the rectangular slot in the motor mount bracket is in line with the pulley.

2. Install the motor (E) on the motor mounting bracket (A) with the bolts (C) and nuts (D).
3. Install the tensioner bracket (H) to the left side vertical brace (B) with the bolts (F) and nuts (G).
4. Align the keyway and insert the pulley (I) on the motor shaft.
5. Make sure the motor pulley, tensioner (J) and fan pulley (I) are in a straight line. Secure the motor pulley to the shaft using the set screw.

Figure 3-7 Motor installation

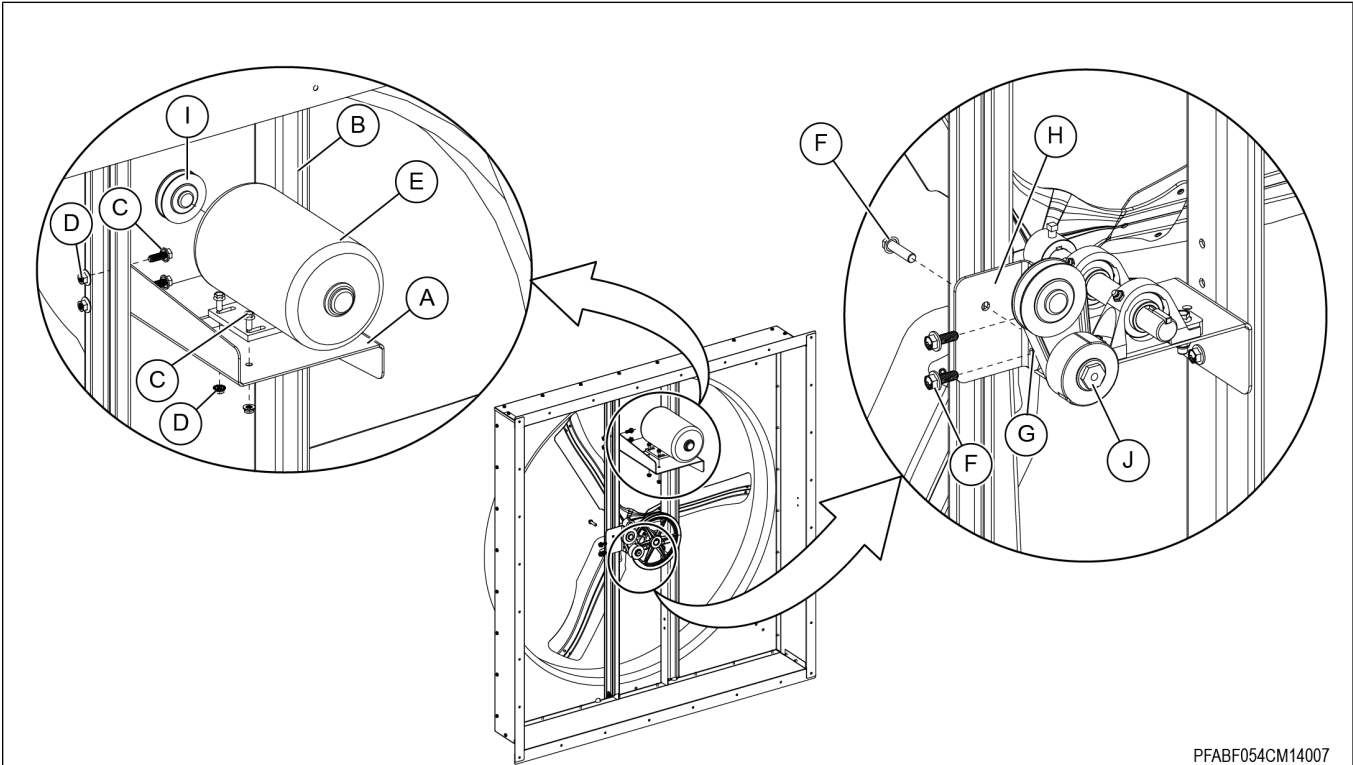

PFABF054CM14007

A	Motor mounting bracket (12-0213)	F	Bolts (S-6606)
B	Vertical braces (12-0210)	G	Nuts (S-10268)
C	Bolts (S-7485)	H	Tensioner bracket (12-0211)
D	Nuts (S-968)	I	Fan pulley (12-0493)
E	Motor (15-0212)	J	Belt tensioner (91-0057)

Chapter 3: Assembly

6. Wrap the belt (L) around the motor pulley (K), driven pulley (I) and tensioner arm pulley (J).

Figure 3-8 Belt installation

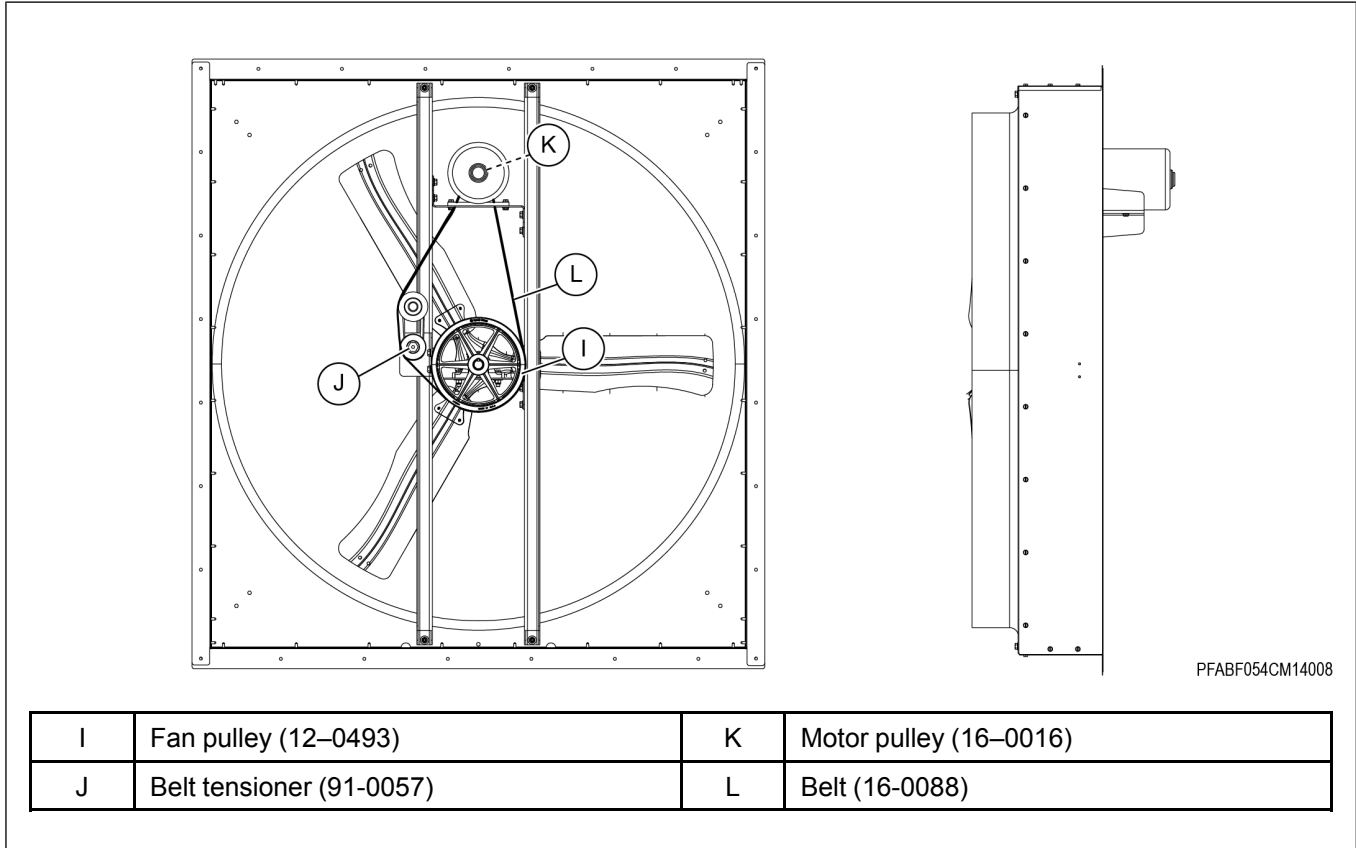

Tabbed Cone Panel Assembly

- 1. Lay the cone panels (A, B, and C) on the ground as shown.
- 2. Attach the four (4) cone panels together using the tab and slot connections on the edges of each panel.

NOTE: Make sure that all the tabs are on the inside of the cone assembly.

- 3. Install the bolts and nuts through the holes where the panels overlap, to hold the four (4) cone panels together.
- 4. Once four (4) cone panels are assembled stand the assembly up with the large radius (E) side down.
- 5. Pull both the ends together to create a heart shape as shown and slide the tabs (F) into the slots.

Figure 3-9 Tabbed cone panel assembly

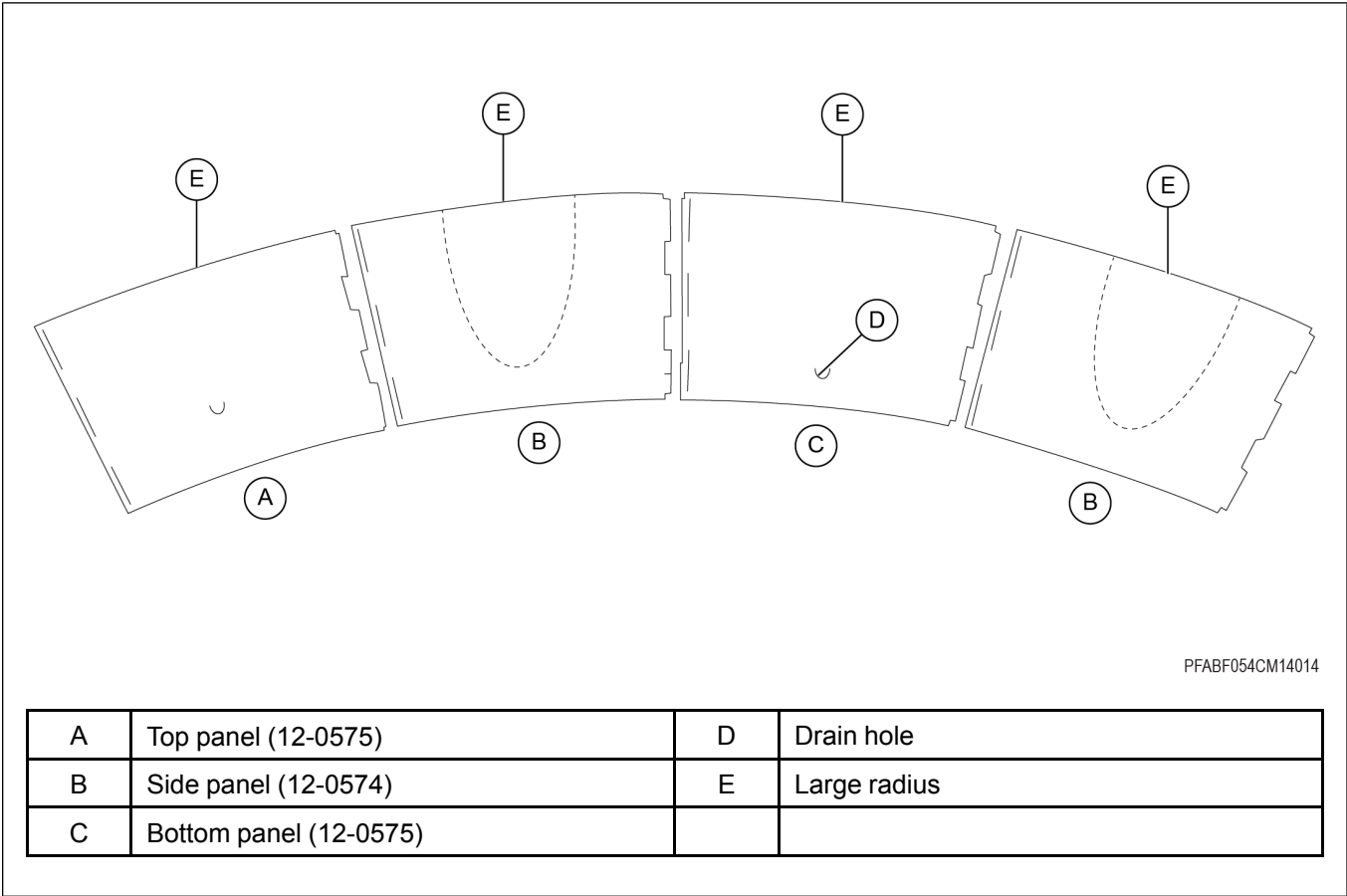
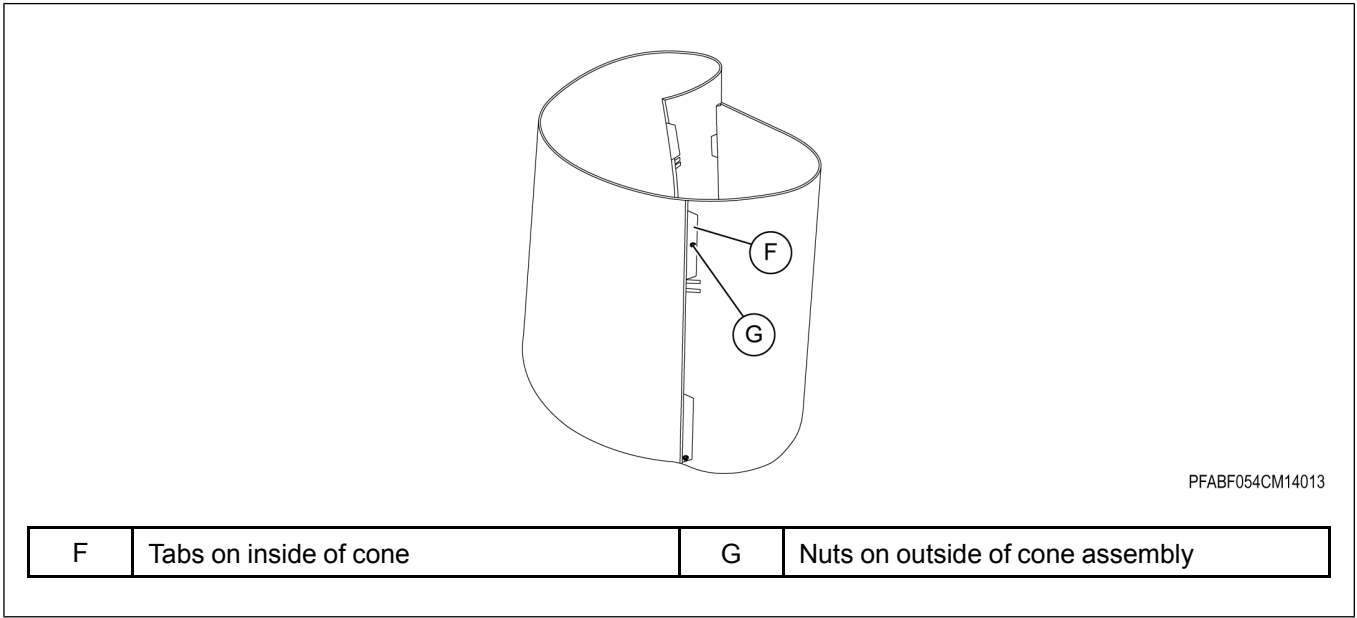

Figure 3-10 Tabbed cone assembly



6. Install the remaining bolts and nuts (G) into place to hold the cone together.

NOTE: Make sure the bolt heads are located on the inside of the cone assembly. Loosely tighten the nuts.

Figure 3-11 Tabbed cone assembly

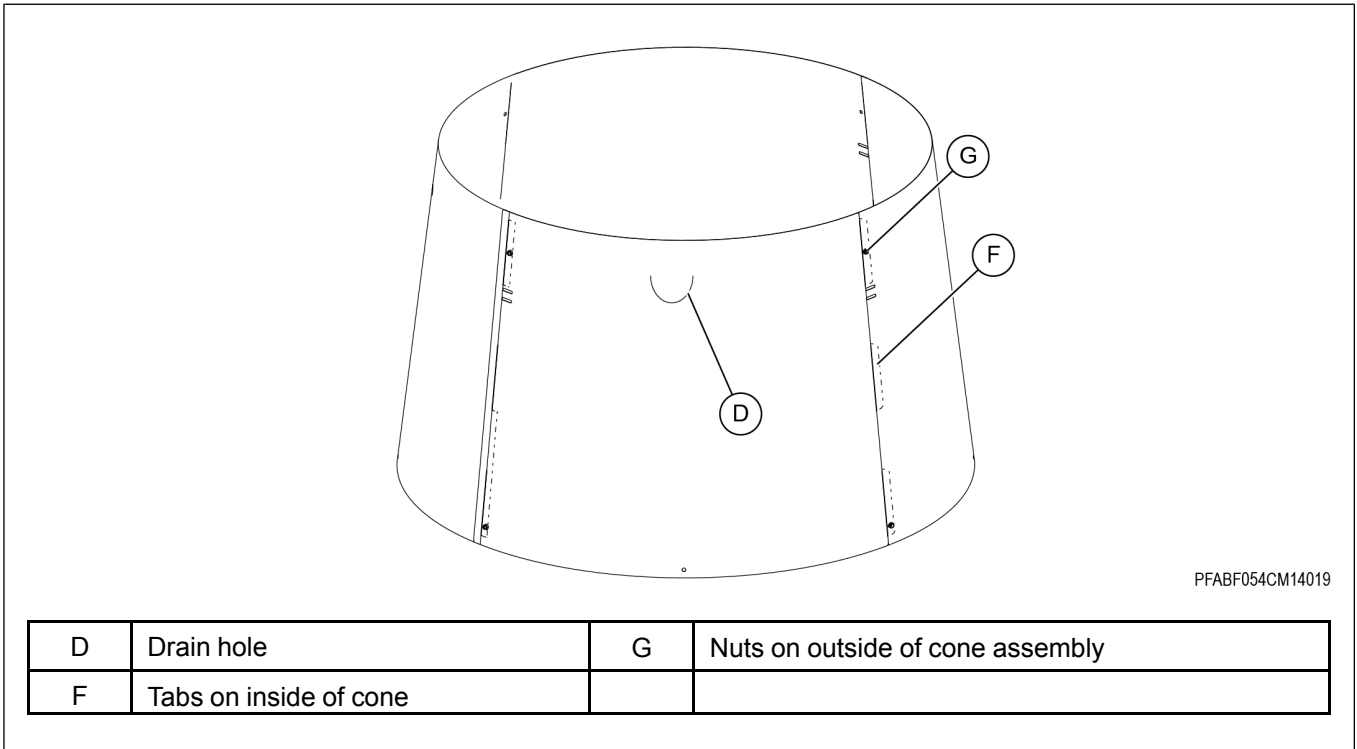

7. Install the assembled cone on the fan cabinet unit using the cone mounting angles (H) and bolts (I).

NOTE: Prior to installing the cone, secure it into mounting holes with bracket using two bolts (I) and two nuts (J) and it is hand tightened.

NOTE: While installing the cone, make sure that the bottom panel with the drain hole (D) is closest to the ground.

Figure 3-12 Cone strut angles

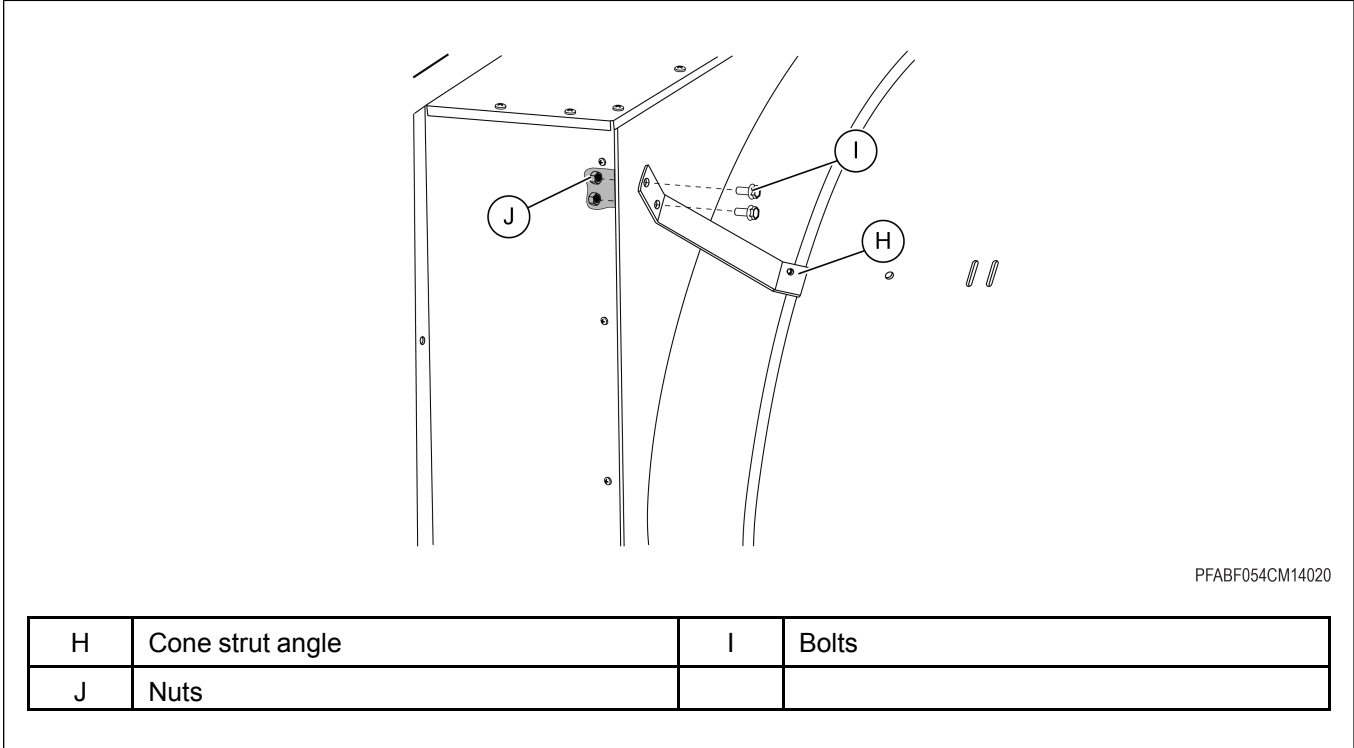

Butterfly Assembly

1. Install the spring clips (B) as shown onto the butterfly frame.
2. Install the shafts (D), washers (E), and mounting blocks (F) in the butterfly flaps (C) as shown.
3. Install the mounting blocks (F) on the butterfly flaps (C) to the butterfly frame (A) top and bottom with the bolts (G) and nuts (H).
4. Install the spring (I) to the flaps (C) with the bolts (G) and nuts (H).

Figure 3-13 54 in. Butterfly frame assembly

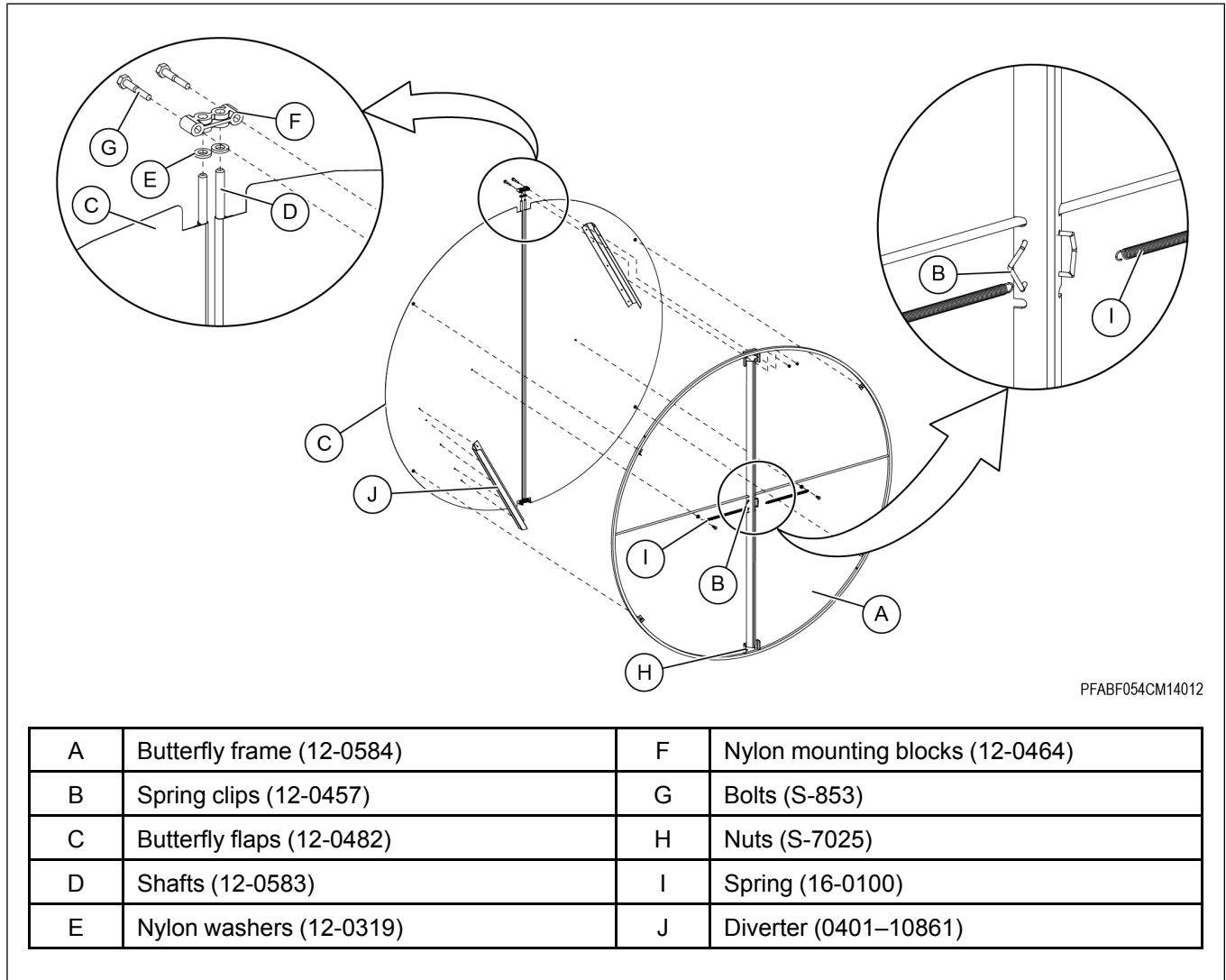

5. The V-shaped center bar of the butterfly frame weldment should be positioned vertically, with the bottom lining up with the slots farthest out on the cone (L) and the top lined up with the slots farthest in on the cone (K). This will give the butterfly frame weldment a slight tilt back (~ 1 in.). This aids the closing of the butterfly flaps.
6. Use 1/4 in. x 1-1/4 in. bolts and nuts to fasten the butterfly frame weldment to the panels. Tighten the 1/4 in. nuts.

Figure 3-14 Butterfly flaps installation

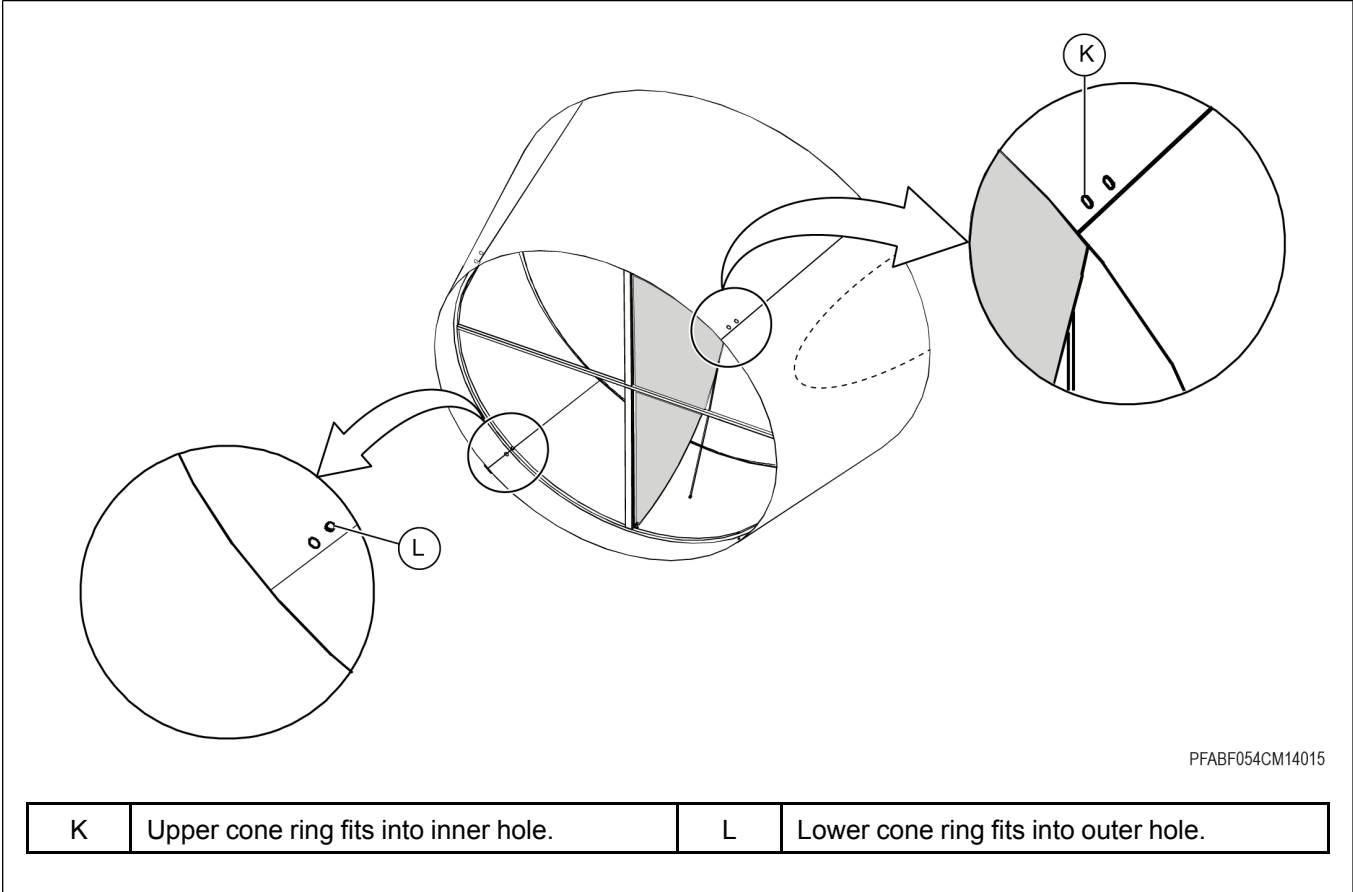

NOTE: Fan not shown for clarity.



Fan ring must be plumb and level in order for doors to operate properly.

- 7. Attach the springs (I) from the flaps (C) to the spring clip (B).
- 8. Push the flaps open and make sure that the flaps close automatically from the spring tension, completely sealed by the magnets on the butterfly frame weldment assembly.

Figure 3-15 Grill guard with flat sides

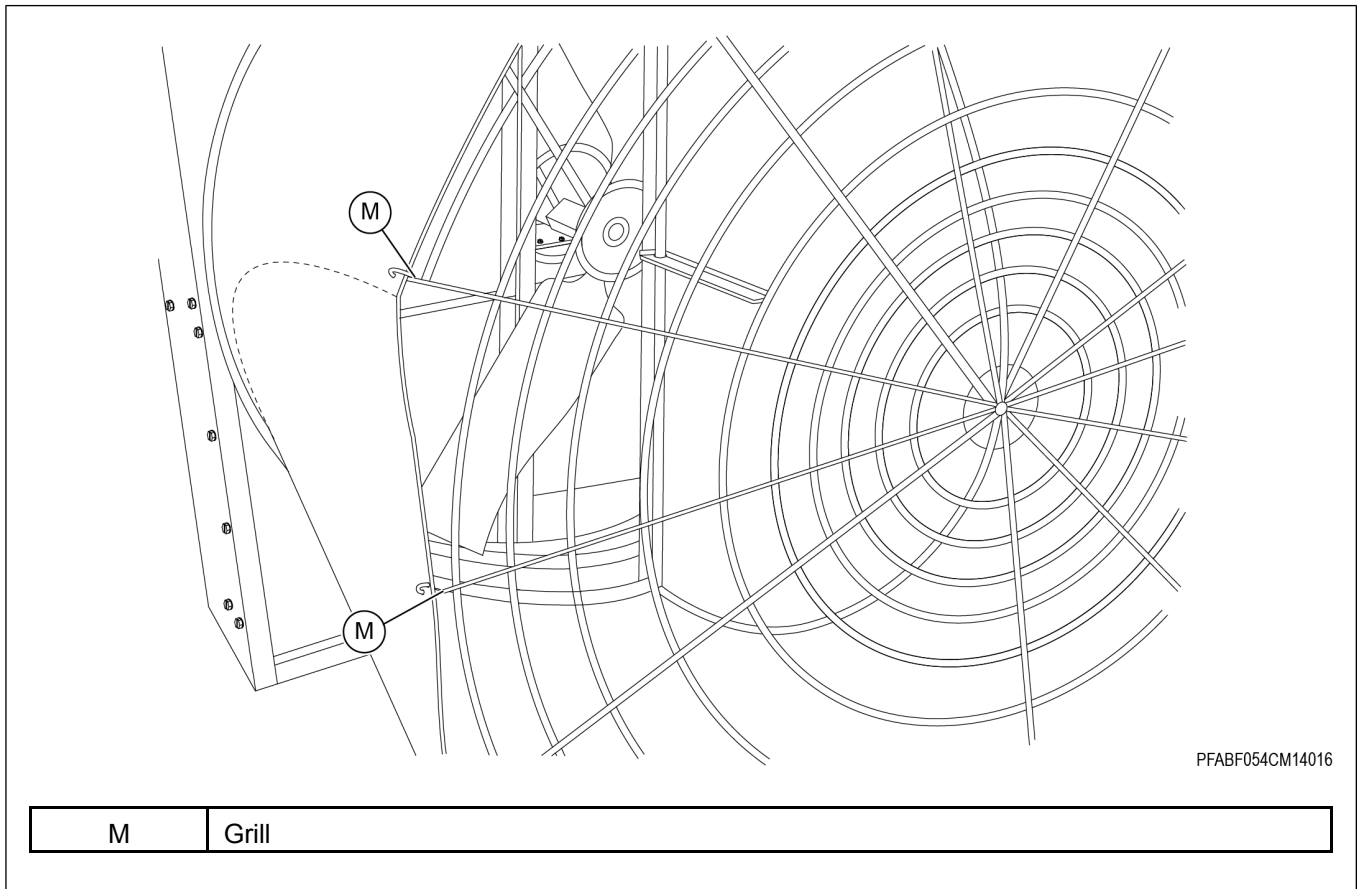

9. To reduce the cone diameter from 72 in. to 64 in. side to side, clip the two (2) side wires of the grill (M) on both sides.
10. Using a rubber mallet hammer along the "Arches" formed on both side panels until they flatten as shown. If needed, use the supplied 5/16 in. x 1-1/4 in. bolts to connect adjacent side cone panels that will meet flush.

Grill Guard Assembly

- 1. Position the grill guard (A) in front of the cone panel (B) and make sure the eyelets (E) on the grill aligns with the holes in the cone panels at all positions.
- 2. Install the grill guard (A) to the cone assembly (B) using the bolts (C) and whiz nuts (D).

Figure 3-16 Grill guard assembly

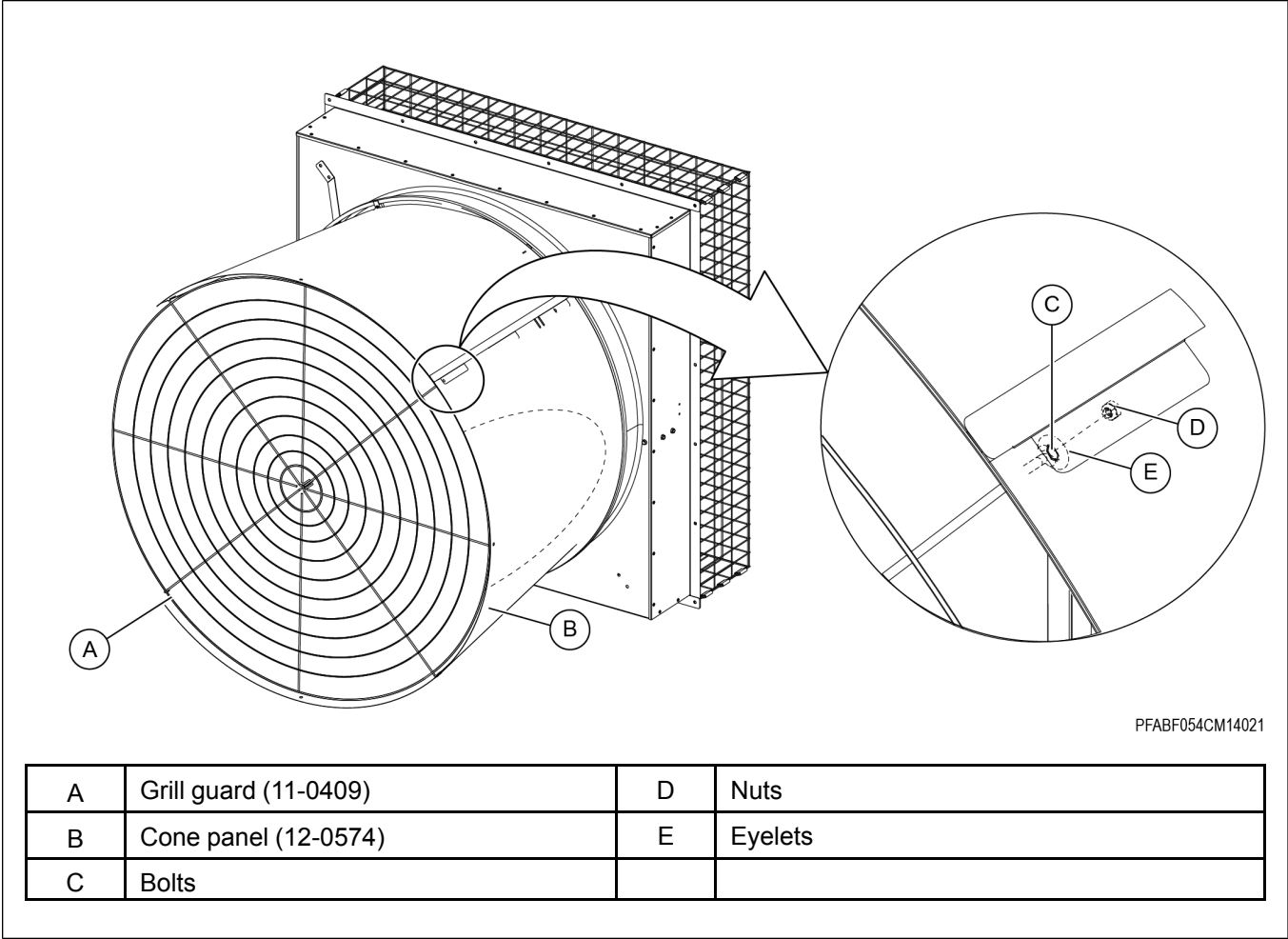

Inlet Grill Assembly

1. Attach the side grills (A) to the top and bottom grills (B) together with clips (D). Crimp the clips.
2. Attach the front grill (C) to the sides using the clips (D). Crimp the clips.
3. Install the hanging hooks (E) on the four corners of the fan cabinet assembly (F).
4. Install the assembled front grill (C) to the hanging hooks as shown.

Figure 3-17 54 in. Inlet grill assembly

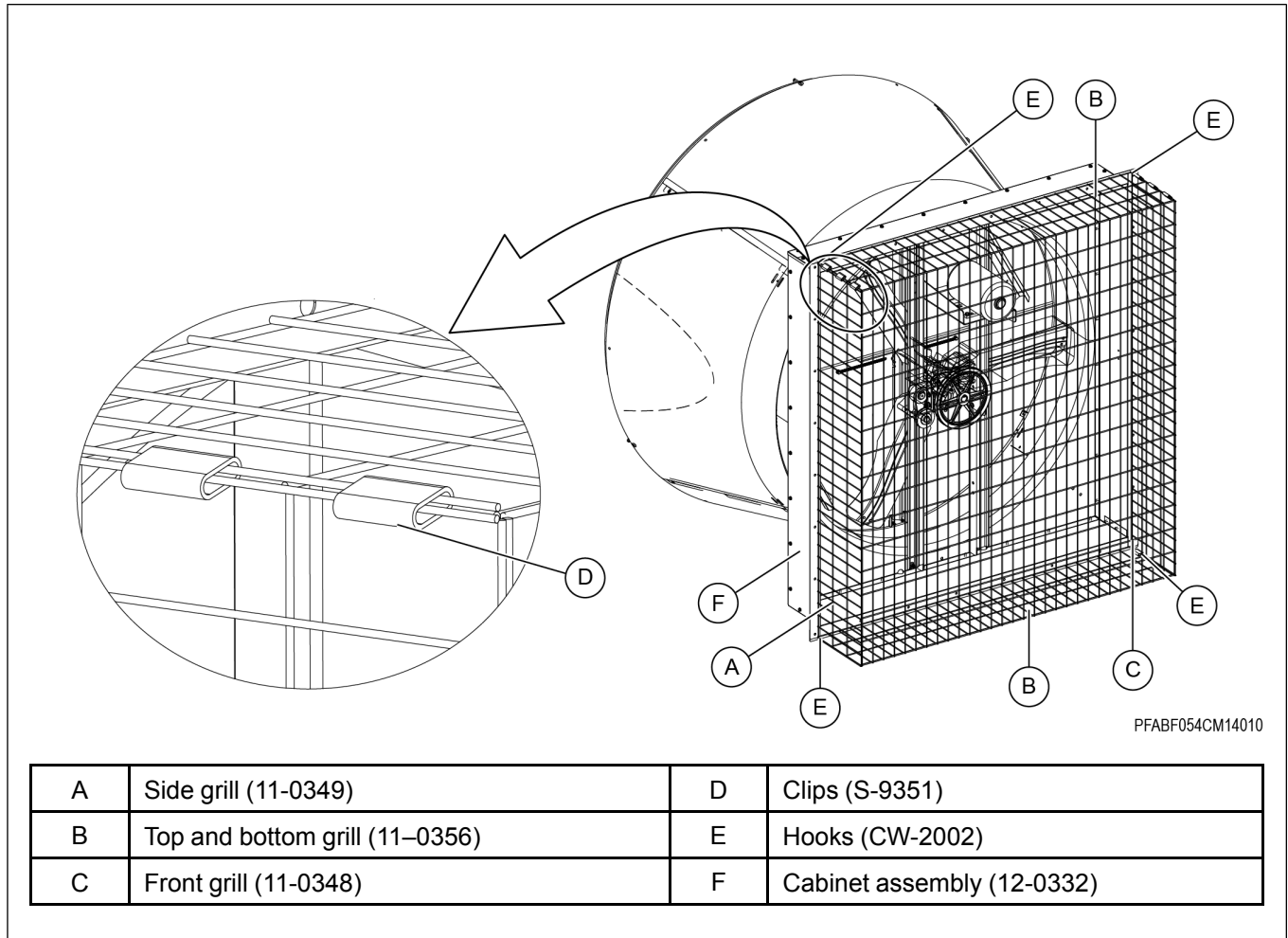

Inlet Bell Assembly

- 1. Install the inlet bell rest bracket (A) to the bottom panel (C) using the provided wood screws (B).

Figure 3-18 Inlet bell rest bracket

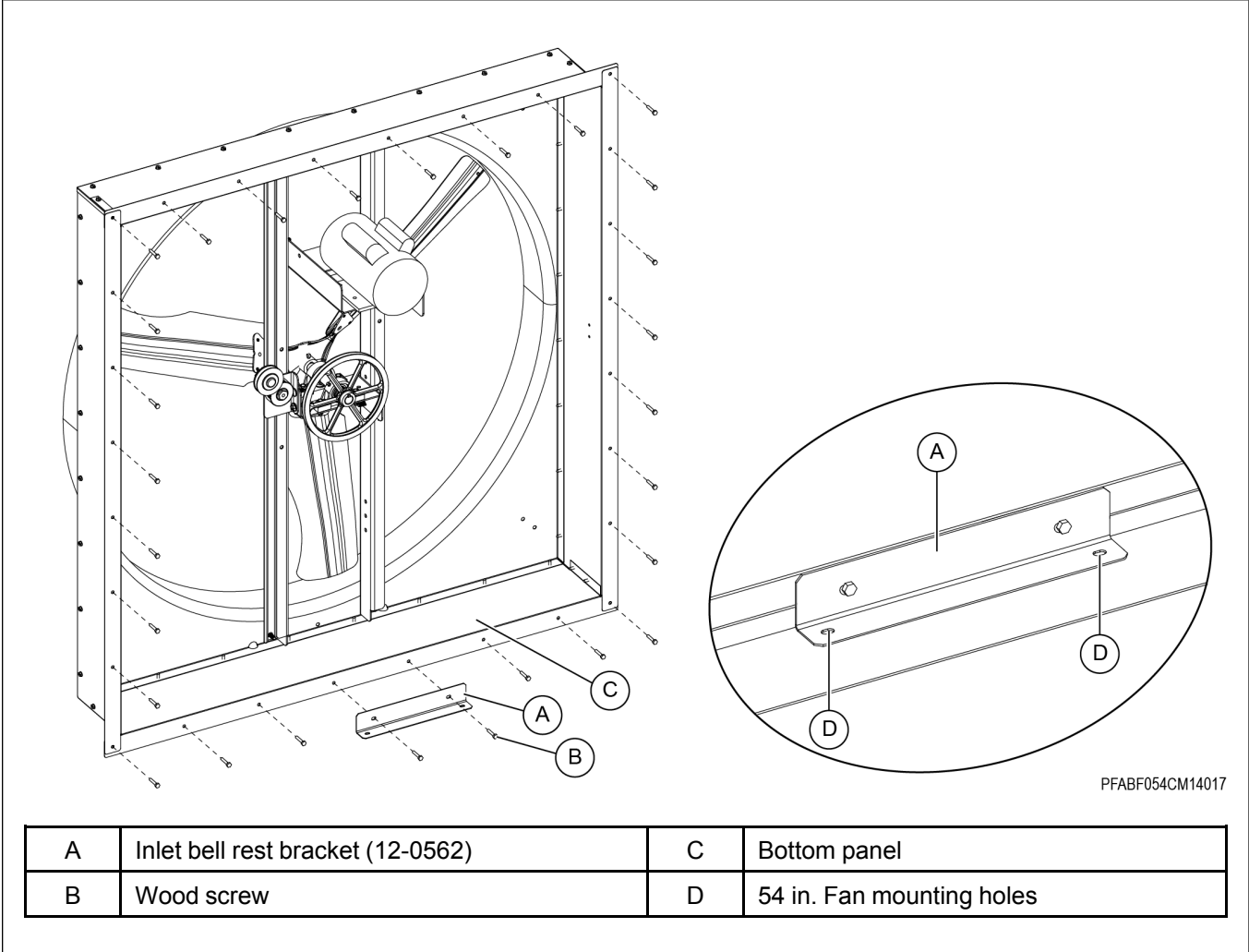

PFABF054CM14017

Chapter 3: Assembly

2. Attach the inlet bell (E) to the fan housing by locking into place using the attached over center latches (F).

Figure 3-19 Inlet bell assembly

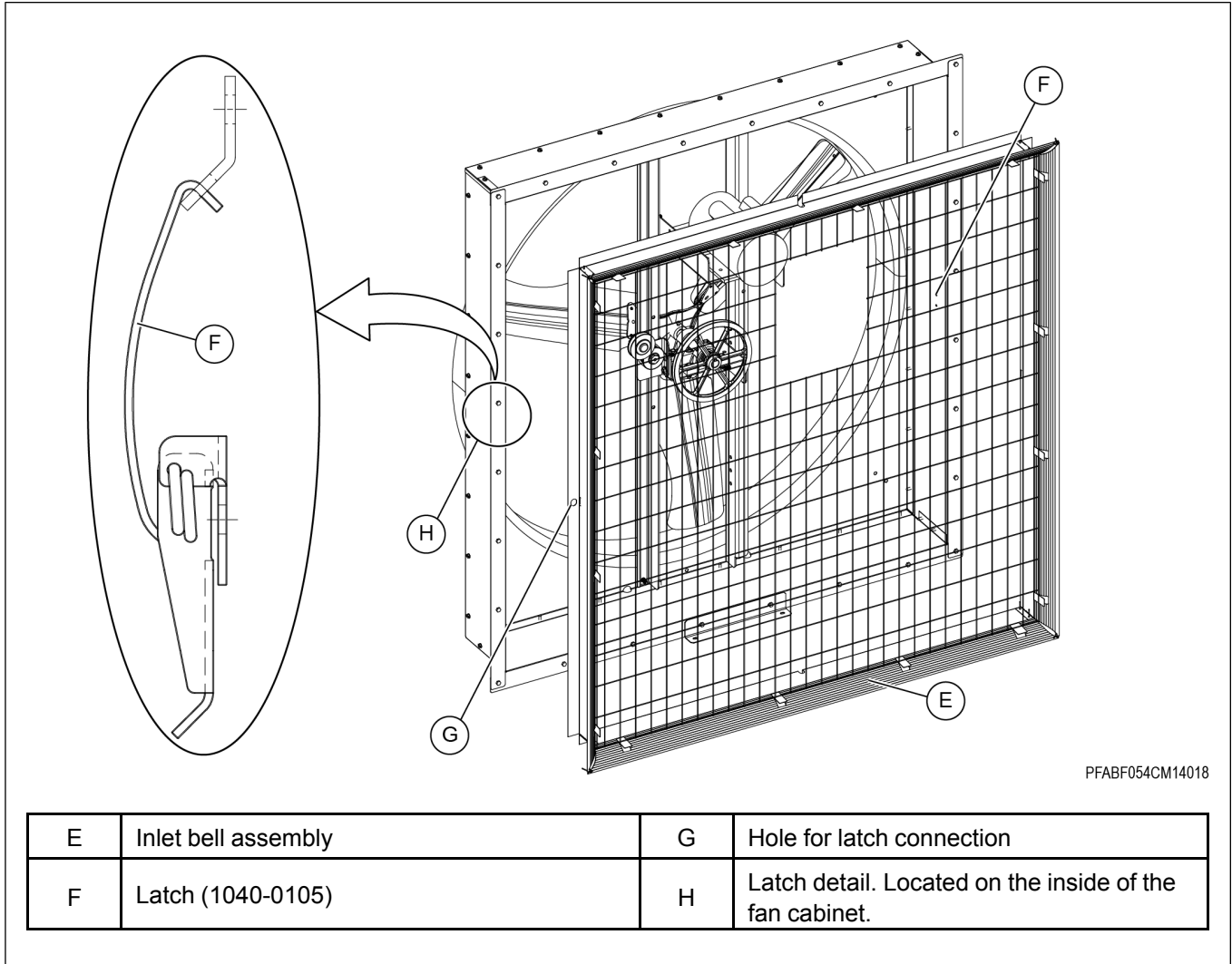

Electrical Connection

Before You Begin

All wiring should be installed in accordance with National, State and Local electrical codes. A certified electrician should complete this portion of the installation to ensure safety and that the wiring is correct for the application.

1. First, remove the back cover of the motor exposing the wiring block.

Figure 3-20 Wiring connections

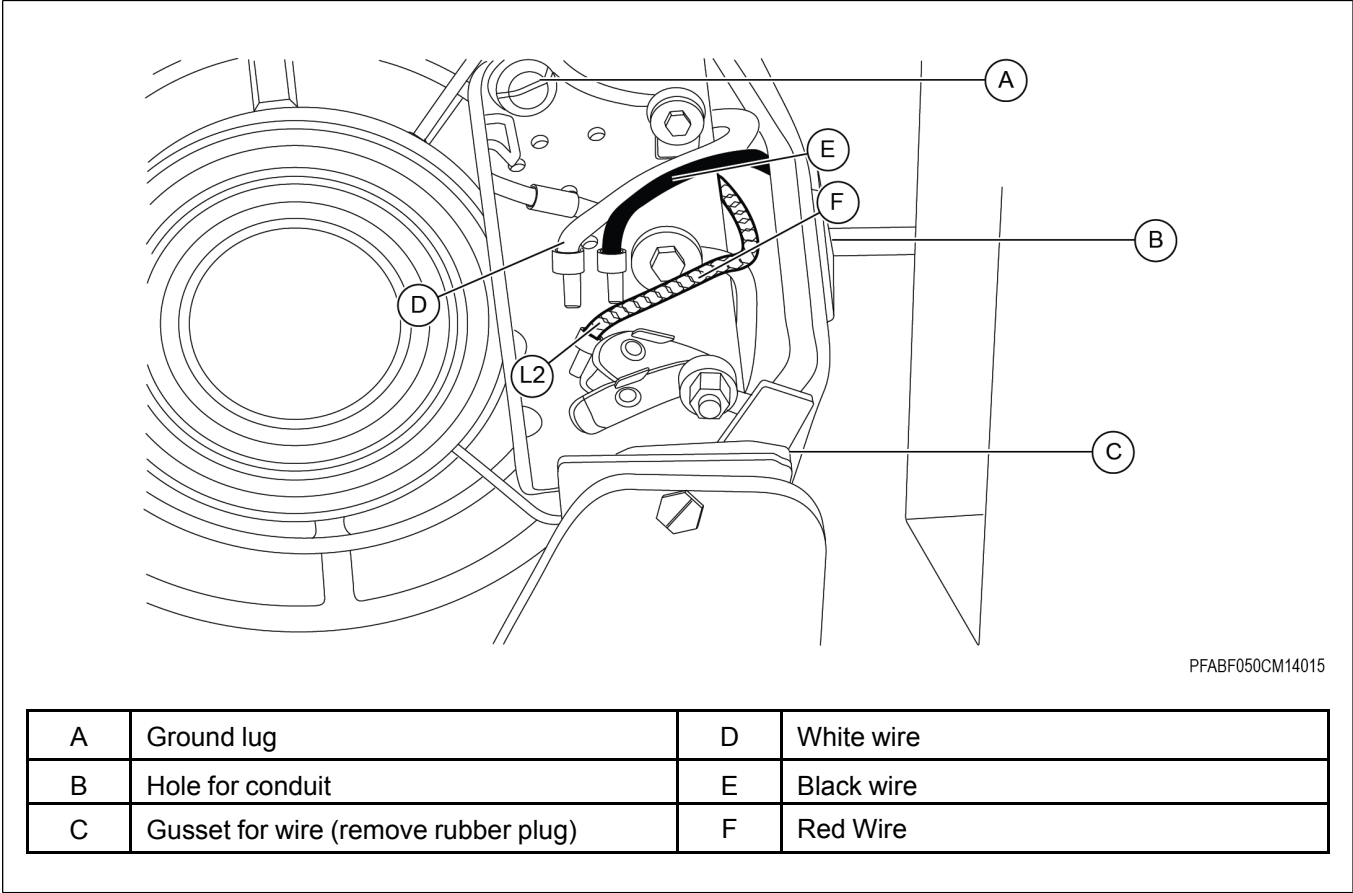

2. The motor is designed to use either a solid clamping conduit on the side of the motor or the supplied wire with a three-prong plug attached. In either case, it is important to attach the ground wire to the ground lug (A) as depicted.
3. For correct motor rotation (CCW), the Red wire (F) should be located on the L2 connection as depicted. If this is not the case, switch the Red (F) and Black (E) wires. Refer to wiring diagram on the side of the motor for correct wiring for 115V and 230V supply.
4. Fans used to ventilate livestock buildings or other rooms where continuous air movement is essential should be connected to individual electrical circuits with a minimum of two (2) circuits per room. For connection requirements refer to diagram on the motor nameplate.

Chapter 3: Assembly

5. For single phase fans, motor overload protection should be provided for each fan.
6. A safety cut-off switch should be located next to each fan. A circuit breaker switch or slow blow motor type fuses must be used. 3 Phase fans require three (3) pole contactors with overload protection.

Figure 3-21 *Electrical connections*

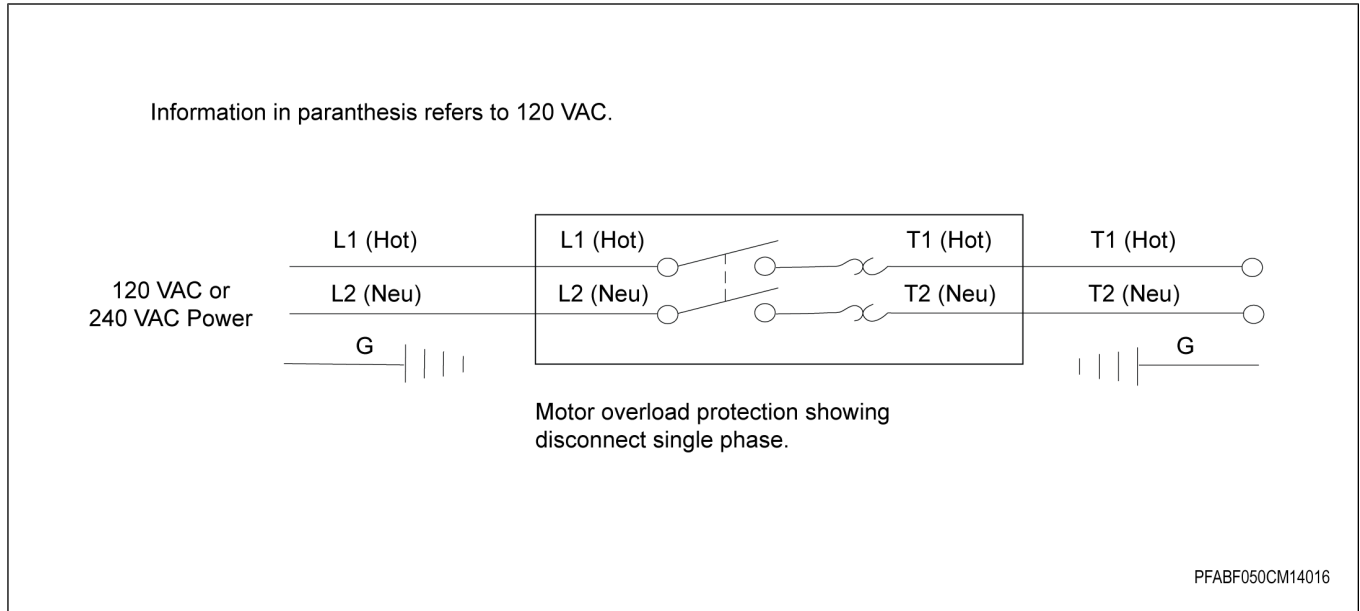

4 Operation and Maintenance

Topics Covered in this Chapter

- Start-Up Operation
- Maintenance

Start-Up Operation



Disconnect and lock out all power sources before servicing equipment.

1. With the fan unplugged, rotate the propeller by turning the fan pulley, look for clearance between the propeller tip and the housing.
2. Replace all guards and check all fasteners to ensure they are tight.
3. When satisfied, energize the fan and make note of direction of rotation.

NOTE: *Make sure the propeller turns counterclockwise when viewed from inside the house and the butterfly flaps should open completely.*

4. The butterfly flaps are designed to stay open during fan operation and close when the fan is de-energized.
5. If the propeller is turning backwards, the flaps will not open. If this is the case, refer to *Electrical Connection* and switch the black and red wires as noted after de-energizing the fan.
6. Re-check the operation and when satisfied the fan is operating properly, follow the instructions below.

Maintenance



Disconnect and lock out all power sources before servicing maintenance.

1. Check the belt, pulleys and the bearings after every two (2) months of service.
2. The belt tensioner should be positioned between the second and the third notch as indicated by the mark on the body of the tensioner. Under tensioning will result in belt slippage, over tensioning will lead to premature belt and bearing failure.
3. The motor and shaft bearings are lubricated at the factory.
4. The motor bearings should never require lubrication over the life of the motor.
5. Pillow block bearings should be re-lubricated every 30 operating days and/or after each wash down cycle with three (3) shots of grease or until fresh grease is seen purging past seal.

Chapter 4: Operation and Maintenance

6. Lithium or lithium-complex based #2 NLGI grease must be used. Other types of grease are incompatible with the factory lubricant and will damage the bearing. **Incompatible grease or lack of service will void bearing warranty.**



DO NOT use a pneumatic or powered grease gun.

7. **When cleaning the fans, Do Not Spray bearings, tensioner or motor directly with a pressure washer as this will lead to premature failure of these components.**
8. After cleaning the fan, simply wipe these parts with a clean rag to remove dirt and debris. Failure to follow these instructions will void the warranty on these components.

5 Troubleshooting

Topics Covered in this Chapter

- Troubleshooting Guide

Troubleshooting Guide

Symptom	Probable Cause(s)	Corrective Action(s)
Excessive noise.	Defective motor bearing.	Replace.
	Defective pillow block bearing.	Replace.
	Parts are not securely anchored.	Check all bolts, screws and fasteners.
	Damaged fan blade.	De-energize fan. Turn prop and check tip clearance. Do they appear to be approximately the same? NOTE: <i>They can be a little different without any problems.</i> If they are significantly different, contact your distributor for more information.
Fan inoperative.	Electricity is turned OFF.	Contact local utility supplier.
	Belt is broken.	Replace.
	Defective motor.	Replace.
	Open power supply circuit.	Replace fuse or reset circuit breaker. Check for disconnected, cut or damaged power cord.
Insufficient airflow.	Intake/exhaust shutter is jammed/clogged.	Repair/replace/clean as necessary.
	Inlet/outlet guards clogged by dirt/debris.	Repair/replace/clean as necessary.
	Voltage supplied is not correct (must be within $\pm 10\%$ of the nominal voltage).	Check line voltage at motor, verify wiring. Check with local utility supplier for possible line problems.
Excessive vibration.	Fan blade has excessive dirt build-up.	Clean unit.
	Motor/drive shaft is bent.	Replace.
	Fan blade is bent or otherwise damaged.	Replace blade. Apply anti-seize lubricant to the shaft.

Chapter 5: Troubleshooting

Symptom	Probable Cause(s)	Corrective Action(s)
Motor overheats and overload trips.	Intake/exhaust shutter is jammed/clogged.	Repair/replace/clean as necessary.
	Inlet/outlet guards clogged by dirt/debris.	Repair/replace/clean as necessary.
	Motor has excessive dirt build-up.	Clean unit.
	Fan blade has excessive dirt build-up.	Clean unit.
	Building operating static pressure too high.	Adjust air inlets to lower static pressure.
	Power supply voltage is too low.	Check line voltage at motor; verify wiring is of sufficient gauge for load and length of conductor. Check with local utility supplier for possible line problems.

6 Parts List

Topics Covered in this Chapter

- 54 in. Mega Flow Fan Parts

54 in. Mega Flow Fan Parts

Table 6-1 Motor Part Numbers

Model Number	Part Numbers		
	Motor Part Number (C)	Driven Pulley Part Number (H)	Motor Pulley Part Number (I)
77-0143 and 77-0155	3017-3101	12-0493	1011-2638
77-0144 and 77-0156	3017-3101	16-0099	1011-2638
77-0145 and 77-0157	3017-3101	16-0015	1011-2643
77-0146 and 77-0158	3017-3101	16-0015	16-0103
77-0147 and 77-0159	3017-3101	12-0493	16-0016
77-0148 and 77-0160	3017-3101	16-0099	16-0016
77-0149 and 77-0161	3017-3101	16-0015	017-1422-9
77-0150 and 77-0162	3017-3101	12-0493	1011-2643
77-0151 and 77-0163	15-0212	16-0099	1011-2643
77-0152 and 77-0164	3017-5109	16-0015	1011-2643
77-0153 and 77-0165	3017-5109	12-0493	1011-2638
77-0154 and 77-0166	3017-5109	16-0099	16-0016

54 in. Mega Flow Fan Parts

Figure 6-1 54 in. Galvanized Mega Flow Butterfly Fan Parts

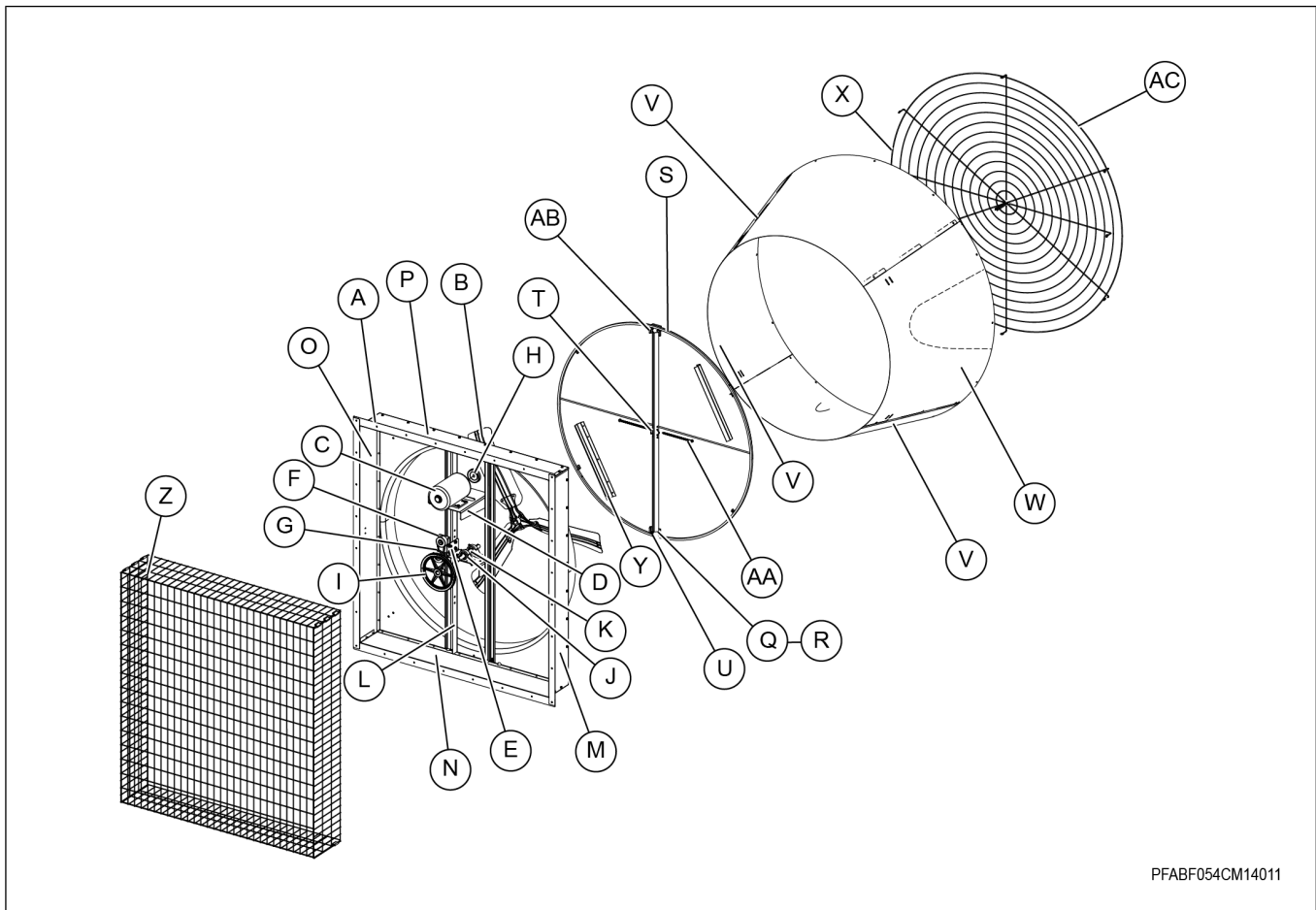

PFABF054CM14011

Table 6-2 54 in. Galvanized Mega Flow Butterfly Fan Parts

Callout	Part Number	Description	Qty
A	12-0332	54 in. Galvanized Butterfly Fan Venturi 57 in. x 60-1/2 in.	1
B	13-0227	Propeller, 54 in. Mega Flow Butterfly Galvanized Fan (3 Blade)	1
C	15-0212	Motor, 1.5 HP, 115/230 VOLTS, 60/50 HZ (See Motor Chart)	1
D	12-0213	Motor Mount Bracket 54 in. Galvanized Fan	1
E	12-0212	Bearing Bracket 54 in. Galvanized Fan	1
F	12-0211	Tensioner Bracket 54 in. Galvanized Fan	1
G	91-0057	Rotary Belt Tensioner with Splash Guards	1
H	See table	Sheave, AK34 x 5/8 in. Groove	1
I	See table	Pulley, Fenner Nylon AFD 9.93 in. with 1 in. Bore	1
J	13-0226H	Pillow Block Cast Bearing Assembly	2
K	12-0217	Shaft 1 in. Diameter 54 in. Galvanized Fan	1
L	12-0210	Vertical Brace 54 in. Galvanized Fan	2
M	12-0461	Right Panel 54 in. Galvanized Butterfly Fan	1
N	12-0459	Bottom Panel 54 in. Galvanized Butterfly Fan	1

Table 6-2 54 in. Galvanized Mega Flow Butterfly Fan Parts (cont'd.)

O	12-0460	Left Panel 54 in. Galvanized Butterfly Fan	1
P	12-0458	Top Panel 54 in. Galvanized Butterfly Fan	1
Q	12-0464	Block, Nylon Mounting	2
R	12-0319	Nylon Washer	2
S	12-0584	Butterfly Fan Flap - 54 in. Galvanized Fan	2
T	12-0457	Spring Clip Mounting - 54 in. Butterfly Fan	2
U	12-0578	54 in. Galvanized Butterfly Fan Sub-Assembly	1
V	12-0575	54 in. Galvanized Butterfly Fan Top and Bottom Cone Panel	2
W	12-0574	54 in. Galvanized Butterfly Fan Side Cone Panel	2
X	11-0409	Guard 70-5/8" 54" Galvanized Butterfly Fan	1
Y	0401-10861	Diverter 54 in. Damper (3 Bend)	2
Z	11-0351	54 in. Galvanized Butterfly Fan Inlet Grill Assembly	1
AA	S-1429	Bolt, HHCS 1/4-20 x 3/4 in. ZN Grade 2	4
AB	S-7025	Nylock Nut 1/4-20 in. ZN Grade 5	2
AC	11-0350	Guard, 64-1/2" 54" Galvanized Butterfly Fan	
N/S	10-0135	Kit 54 in. Galvanized Butterfly Fan	1
N/S	11-0351	Inlet Grill Assembly 54 in. Butterfly Fan	1
N/S	6403-3181	54 in. Galvanized Butterfly Fan Inlet Bell Assembly (Optional)	1
N/S	16-0097	Belt, AX60 Cogged V-Belt, 62 in. Nominal Length	1
N/S	DC-1540	Decal, Danger/Warning	2
N/S	DC-1571	Decal, Grease Instructions All BD Fans	1
N/S	DC-983	Decal, AVS Logo 10 in. x 2 in.	2
N/S	DC-995	Decal, Warning Shear Point	2
N/S	S-248	Flat Washer 3/8 in. 7/16 in. I.D. 1 in. O.D. YDP	8
N/S	S-10268	Flange Nut 5/16-18 JS Grade 5	4
N/S	S-6606	Flange Bolt 5/16-18 x 3/4 in. ZN Grade 5	4
N/S	S-7383	Nylock Nut 3/8-16 in. ZN Grade 5	4
N/S	S-7485	Flange Bolt 3/8-16 x 1 in. JS Grade 8 or Grade 8.2	14
N/S	S-9168	Square Key 1/4 in. x 1 in.	2
N/S	S-9265	Screw, SMSA 1/4-14 x 5/8 in. HWHS ZN	40
N/S	S-9303	Flange Bolt 3/8-16 x 1-1/2 in. YDP Grade 8	5
N/S	S-968	Flange Nut 3/8-16 in. ZN Grade 5 Wide Flange	14
N/S	12-0318	Galvanized Flap Shaft 54 in. Butterfly Fan	2

NOTES

GSI Group, LLC Limited Warranty

The GSI Group, LLC ("GSI") warrants products which it manufactures to be free of defects in materials and workmanship under normal usage and conditions for a period of 12 months after sale to the original end-user or if a foreign sale, 14 months from arrival at port of discharge, whichever is earlier. The end-user's sole remedy (and GSI's only obligation) is to repair or replace, at GSI's option and expense, products that in GSI's judgment, contain a material defect in materials or workmanship. Expenses incurred by or on behalf of the end-user without prior written authorization from the GSI Warranty Group shall be the sole responsibility of the end-user.

Warranty Extensions: The Limited Warranty period is extended for the following products:

	Product	Warranty Period
AP Fans and Flooring	Performer Series Direct Drive Fan Motor	3 Years
	All Fiberglass Housings	Lifetime
	All Fiberglass Propellers	Lifetime
AP/Cumberland	Flex-Flo/Pan Feeding System Motors	2 Years
Cumberland Feeding/Watering Systems	Feeder System Pan Assemblies	5 Years **
	Feed Tubes (1-3/4" and 2.00")	10 Years *
	Centerless Augers	10 Years *
	Watering Nipples	10 Years *
Grain Systems	Grain Bin Structural Design	5 Years
Grain Systems Farm Fans Zimmerman	Portable and Tower Dryers	2 Years
	Portable and Tower Dryer Frames and Internal Infrastructure †	5 Years

* Warranty prorated from list price:
0 to 3 years - no cost to end-user
3 to 5 years - end-user pays 25%
5 to 7 years - end-user pays 50%
7 to 10 years - end-user pays 75%

** Warranty prorated from list price:
0 to 3 years - no cost to end-user
3 to 5 years - end-user pays 50%

† Motors, burner components and moving parts not included.
Portable dryer screens included.
Tower dryer screens not included.

GSI further warrants that the portable and tower dryer frame and basket, excluding all auger and auger drive components, shall be free from defects in materials for a period of time beginning on the twelfth (12th) month from the date of purchase and continuing until the sixtieth (60th) month from the date of purchase (extended warranty period). During the extended warranty period, GSI will replace the frame or basket components that prove to be defective under normal conditions of use without charge, excluding the labor, transportation, and/or shipping costs incurred in the performance of this extended warranty.

Conditions and Limitations:

THERE ARE NO WARRANTIES THAT EXTEND BEYOND THE LIMITED WARRANTY DESCRIPTION SET FORTH ABOVE. SPECIFICALLY, GSI MAKES NO FURTHER WARRANTY OF ANY KIND, EXPRESS OR IMPLIED, INCLUDING, WITHOUT LIMITATION, WARRANTIES OF MERCHANTABILITY OR FITNESS FOR A PARTICULAR PURPOSE OR USE IN CONNECTION WITH: (I) PRODUCT MANUFACTURED OR SOLD BY GSI OR (II) ANY ADVICE, INSTRUCTION, RECOMMENDATION OR SUGGESTION PROVIDED BY AN AGENT, REPRESENTATIVE OR EMPLOYEE OF GSI REGARDING OR RELATED TO THE CONFIGURATION, INSTALLATION, LAYOUT, SUITABILITY FOR A PARTICULAR PURPOSE, OR DESIGN OF SUCH PRODUCTS.

GSI shall not be liable for any direct, indirect, incidental or consequential damages, including, without limitation, loss of anticipated profits or benefits. The sole and exclusive remedy is set forth in the Limited Warranty, which shall not exceed the amount paid for the product purchased. This warranty is not transferable and applies only to the original end-user. GSI shall have no obligation or responsibility for any representations or warranties made by or on behalf of any dealer, agent or distributor.

GSI assumes no responsibility for claims resulting from construction defects or unauthorized modifications to products which it manufactured. Modifications to products not specifically delineated in the manual accompanying the equipment at initial sale will void the Limited Warranty.

This Limited Warranty shall not extend to products or parts which have been damaged by negligent use, misuse, alteration, accident or which have been improperly/inadequately maintained. This Limited Warranty extends solely to products manufactured by GSI.

Prior to installation, the end-user has the responsibility to comply with federal, state and local codes which apply to the location and installation of products manufactured or sold by GSI.

9101239_1_CR_rev8.xml (revised January 2014)

This equipment shall be installed in accordance with the current installation codes and applicable regulations which should be carefully followed in all cases. Authorities having jurisdiction should be consulted before installations are made.



1004 E. Illinois St.
Assumption, IL 62510-0020
Phone: 1-217-226-4421
Fax: 1-217-226-4420
www.gsiag.com



Cumberland is a part of GSI, a worldwide Brand of AGCO.